



Philips Consumer Lifestyle

Service Manual

PRODUCT INFORMATION

- This product meets the requirements regarding interference suppression on radio and TV.
- After the product has been repaired, it should function properly and has to meet the safety requirements as officially laid down at this moment.

TECHNICAL INFORMATION

- Colour : Deep Red
- Power consumption : 1800 W (IEC) 230 V
: 1200 W (IEC) 127 V
- Maximum Air displacement : 33 l/s
- Vacuum : 250 mbar / 25 kPa
- Duststorage capacity : 2 L
- Cord length : 8 m
- Filter system : HEPA cyclone-filtration system
: Permanent motor protection filter
: HEPA exhaust filter
- Net weight : 6 kg

ACCESSORIES

- Nozzle : Tri-Active all purpose nozzle
- Tubes : Metal lacquered telescopic tubes
- Accessories : Brush, crevice nozzle and small nozzle
- Accessory storage : Active accessory storage bridge in handgrip
- Coupling : Button coupling

OPTIONAL (accessories)

- FC8047/02 Filter Cylinder 109 mm + Motor inlet Filter

■ = changed

DISASSEMBLY- AND RE-ASSEMBLY ADVISE

- To open the appliance, first remove the filter cover (item 17).
- Remove the dust bucket including filter.
- Remove the turn plate cover (item 6) after removing the 2 screws (A).
- Remove the 6 screws (B) at the bottom of the appliance. For 2 screws a screwdriver with a 14.5 cm long shank is required. Screwdriver 4322 009 08490 for T15 is suitable for this.
- Lift the upper housing by pulling only the middle of the backside up (use a screwdriver if necessary).

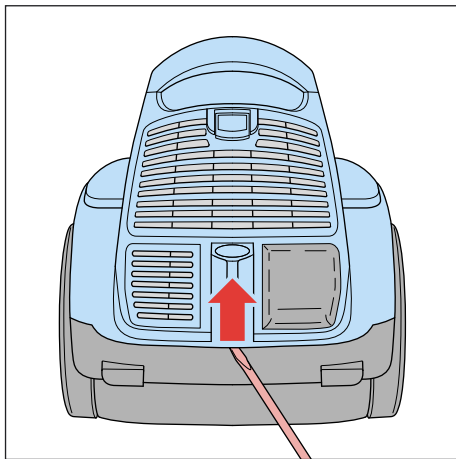

- Remove the potmeter connector from the printed circuit board.
- Do not forget to reconnect the potmeter when re-assembling the upper housing (connector fits in one way only).
- When the repair is finished, check whether all functions of the appliance work properly.

Further disassembly advise for the potmeter:

- Remove the turn knob by just pulling it (use a screwdriver if necessary).
- Remove the 2 screws (C) inside the upper housing, use TORX screwdriver no. T10, which is one of a set consisting of T20; T15; T10; T9; T8; T7 and T6 (code number 4822 395 505145).

REPAIR INSTRUCTION

- The cord winder spring must be tensioned to the maximum level and then be rewound approx 1.5 turns.
- Item 22, air valve, opens to cool the motor if the air displacement is too low or if the airflow is blocked.
- If the function of the electronic control unit is not required, the Triac must be short-circuited in the manner shown in the circuit diagram.

ELECTRICAL DIAGRAM

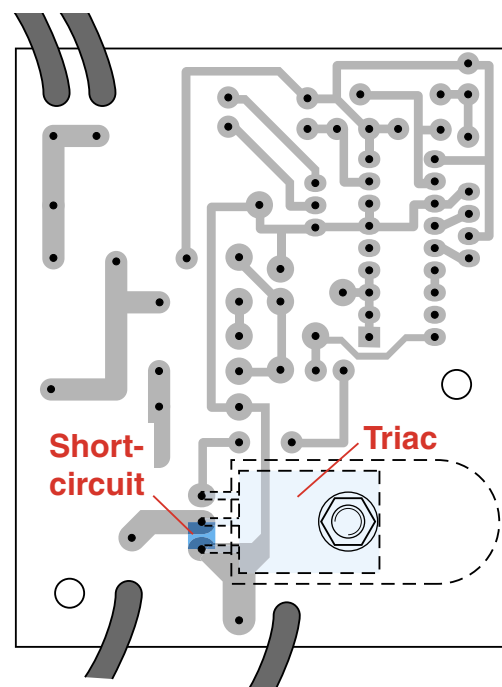
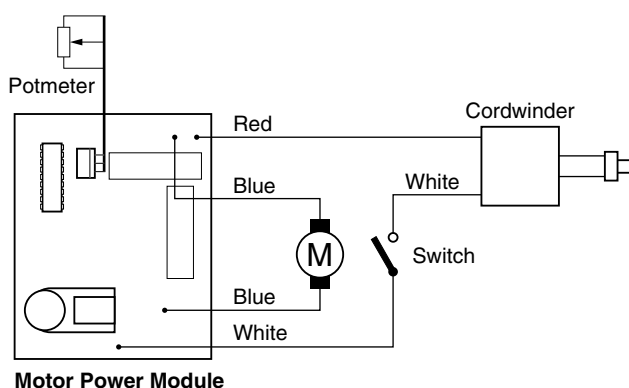

PARTS LIST

FC8734/01 /03

Pos	Service code	Description
1	9965 000 33690	Turn knob
2	9965 000 33726	Upper housing assy Deep Red
3	9965 000 33692	Potmeter kit
4	4322 004 20130	Filter cleaning brush
5	9965 000 33693	Turnplate
6	9965 000 33727	Turnplate cover Deep Red
7	9965 000 33695	Turnplate lever
8	9965 000 33696	PCB Assy
	4222 459 45810	PCB Assy 110 - 127 V
9	9965 000 33697	Air inlet tube A
10	9965 000 33698	Motor cover B
11	9965 000 33699	Air Inlet Sealing
12	4322 004 93310	Air Inlet Filter
13	9965 000 33700	Motor cover B buffer ring
14	9965 000 33701	Motor Cover A
15	9965 000 33702	Dustbucket support
16	9965 000 33703	Motorcover A bufferring
17	9965 000 33728	Backgrille assy Deep Red
19	8838 044 01810	HEPA Filter
20	9965 000 33706	Cooling tube
21	9965 000 33707	Safety valve cover
22	4322 005 19110	Safety valve assy
23	9965 000 33708	Air inlet tube B
24	4222 459 45256	Switch
25	4322 004 93320	Filter assy 109 mm
26	4322 009 09780	Bucket cover assy Grey *
27	4222 459 45207	Dustbucket assy Deep Red
28	9965 000 33711	Cordwinder cover
29	4322 009 09420	Cordwinder assy (no cordset)

Pos	Service code	Description
30	4322 005 17910	Contactplate ass'y
31	9965 000 27733	Caster assy
32	9965 000 33712	Cord outlet
33	4322 000 38820	Silencer A
34	4322 001 73450	Buffer Back
35	9965 000 33713	Silencer B
36	4322 001 73440	Motor buffer front
37	4322 003 26030	Bracket
38	4322 009 09400	Domel service kit
	4322 009 09410	Domel service kit 110 V
39	9965 000 33714	Lower Housing
40	4322 006 01410	Cordset Euro 4.8 pin L = 9.3 m
41	4322 006 01670	Cordset Swiss L = 9.3 m
42	4322 006 01680	Cordset Taiwan L = 6.3 m
43	4322 006 07470	Cordset UK/HK L = 7.3 m
44	4322 003 25510	Curve Bend B1
45	4322 005 19130	Curve Bend B1/Hose assy
46	4322 007 16000	Leafspring
47	4322 003 25560	Crevice Nozzle
48	4322 005 17590	Accessoire bridge assy
49	4341 004 20510	Plumeau assy
50	4822 532 60688	Tube bush
51	4822 492 62163	Tube spring
52	4322 004 23630	Telescopic tube easy touch
53	4322 004 23260	Tri-Active Nozzle stand
54	9965 000 33715	Tap turn assy
55	4341 004 20490	Small Nozzle
58	9965 000 45369	Silencer C

* Standardized colour.

 = changed

EXPLODED VIEW

FC8734/01 /03

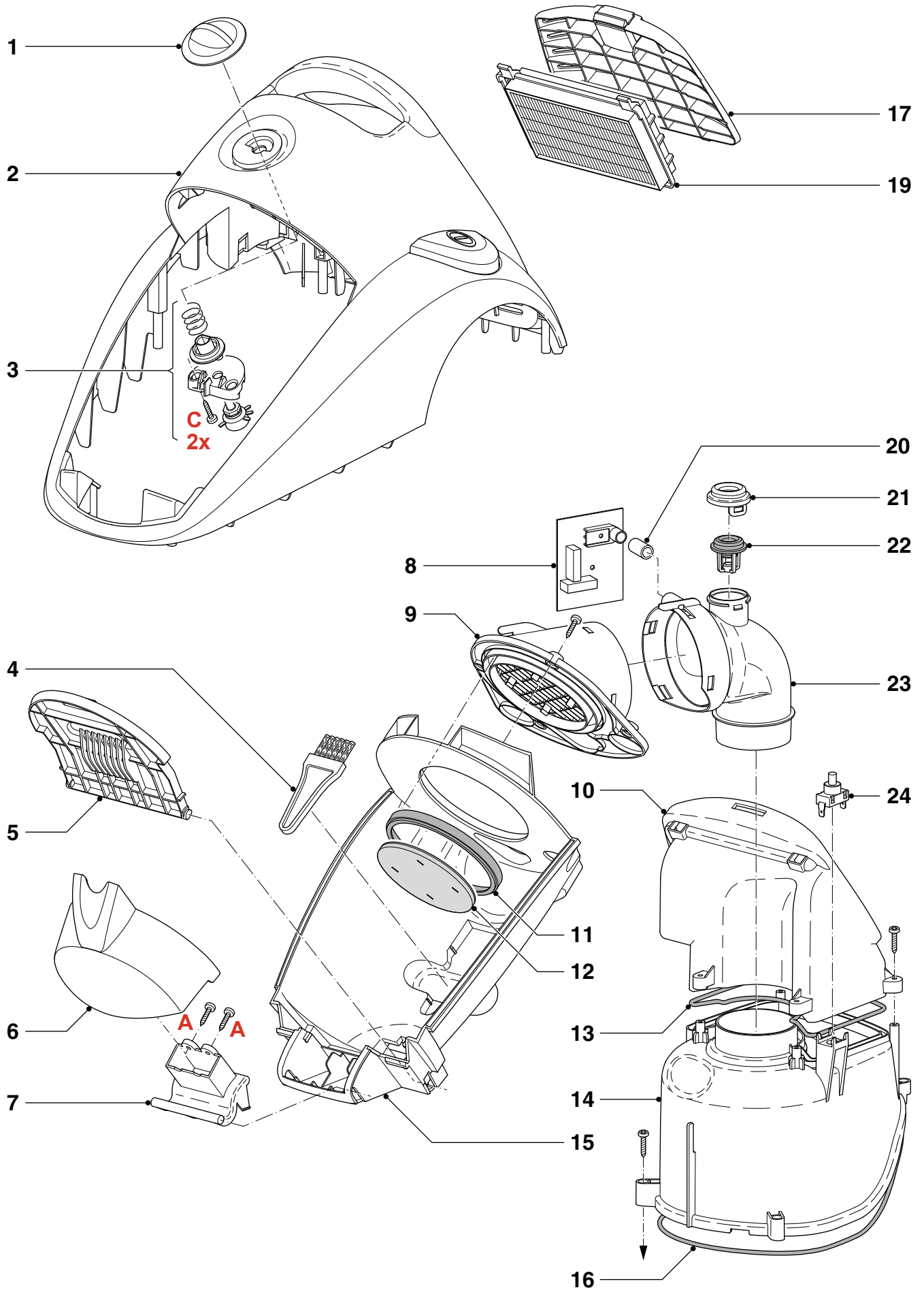

EXPLODED VIEW

FC8734/01 /03

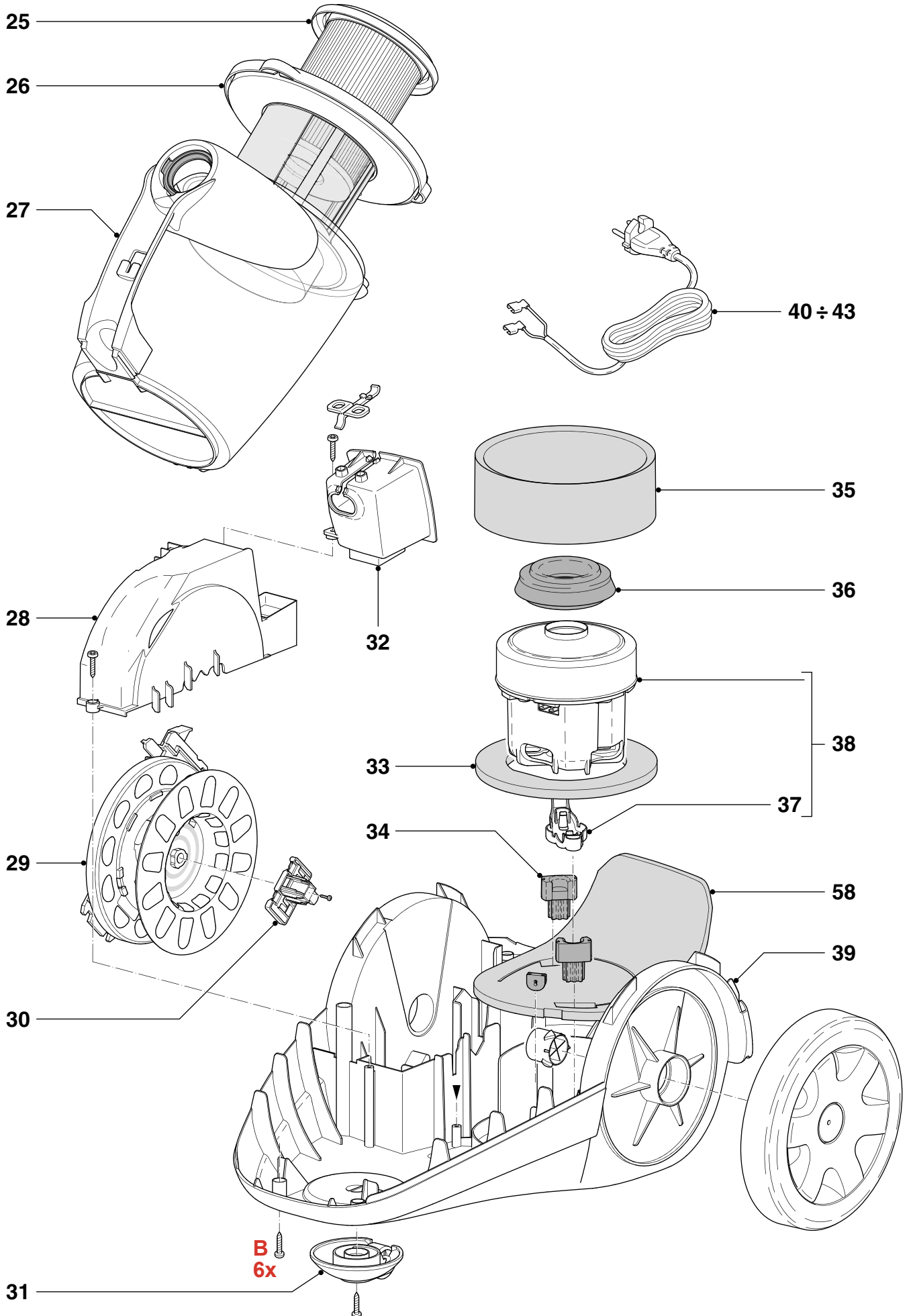

EXPLODED VIEW

FC8734/01 /03

