



Philips Domestic Appliances and Personal Care

Service Manual

PRODUCT INFORMATION

- This product meets the requirements regarding interference suppression on radio and TV.
- After the product has been repaired, it should function properly and has to meet the safety requirements as officially laid down at this moment.

TECHNICAL INFORMATION

- Colour : Deep Red
- Power consumption : 1800 W (IEC) 230V
- Maximum Air displacement : 43 l/s
- Vacuum : 300 mbar / 30.0 kPa
- Type number dustbag : FC8021
- Duststorage capacity : 3 L
- Cord length : 7 m
- Filter system : Double layered compatible s-bag™
: 3 layer permanent motor protection filter
: Super Clean Air exhaust filter
- Dimensions of cleaner : 449 x 324 x 250 mm
- Dimensions of packaging : 593 x 393 x 296 mm
- Net weight : 5.7 kg

ACCESSORIES

- Nozzle : Tri-Active all purpose nozzle
- Tubes : Metal lacquered telescopic tubes
- Accessories : Crevice nozzle and small nozzle
- Accessory storage : Accessory clip on tube
- Coupling : Button coupling

OPTIONAL (accessories)

- FC 8021 : S-bag Classic
- FC 8022 : S-bag Clinic
- FC 8023 : S-bag Anti-Odour
- FC 8024 : S-bag Long Performance
- FC 8025 : S-fresh scent granules
- FC 8030 : Super Clean Air filter, High-Flow AFS exhaust filter
- FC 8031 : Super Clean Air HEPA filter, HEPA12 exhaust filter

DISASSEMBLY- AND RE-ASSEMBLY ADVISE

- To open the appliance, First remove the filter cover (item 24) then remove the vario knob button (item 11) with a screwdriver as shown in the picture.

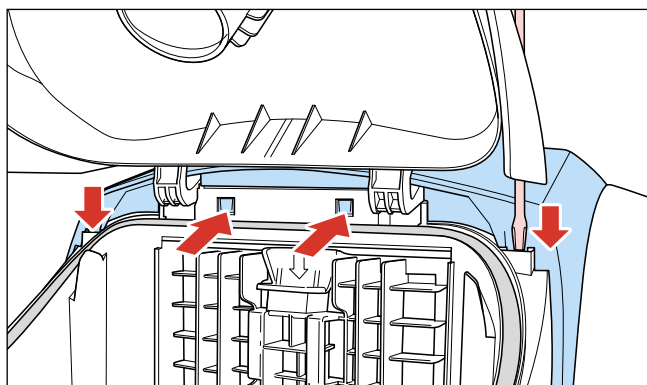
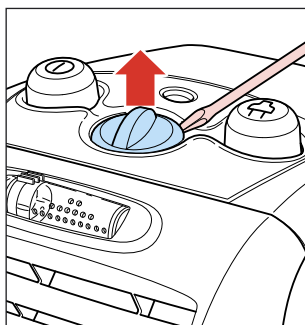

- To remove the button panel (item 13), first loosen mounting screws (A), now by using a screwdriver unlock the 4 snap connection and separate the panel from the housing. (see picture)
- Display cover (item 12) now can easily be removed from the button panel.)
- To remove the motor, you need a torx screwdriver with a 14.5cm long shank. Screwdriver 9965 000 08332 can be used.

REPAIR INSTRUCTION

- Cotton dustbags, are used in countries in which paper dustbags are not available.
- If the reel half spring unit is replaced, shaft G must be lubricated with **silicone grease**. Do not apply any silicone grease to or spill any grease on terminals (39) or conductors (38).
- Item 37 is provided with a long cord-winder spring, but both long and short cords can be used in combination with this spring. (L = 9.3 m)
- Depending on the original cord, the spare cord must be shortened to the length of the original cord.
- The cord winder spring must be tensioned to the maximum level and then be rewound approx. 1.5 turn
- Item 10, air valve, opens to cool the motor if the air displacement is too low or if the airflow is blocked.
- To adjust the telescopic tube (item 46) to the required length, push the adjustment collar in the direction of the arrow while sliding the top section of the telescopic tube into or out of the lower section.
- If the function of the electronic control unit (item 15) is not required, the Triac must be short-circuited in the manner shown in the circuit diagram.
- When the vacuum cleaner is used to suck up fine dust the pores of the dustbag may become clogged, causing the passage of air through the dustbag to become obstructed. As a result, the dustbag-full indicator will indicate that the dustbag needs to be replaced, eventhough the dustbag is not full at all.

ELECTRICAL DIAGRAM

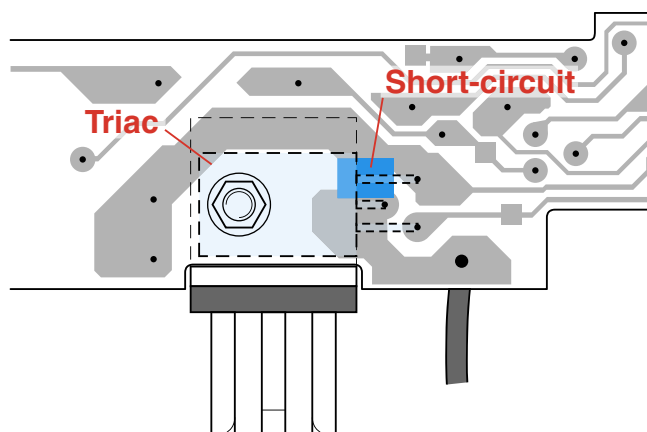
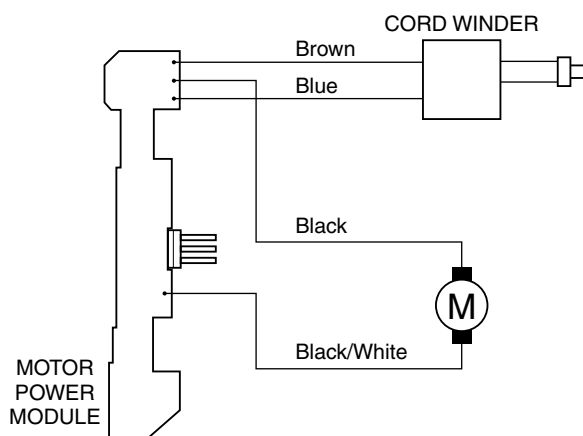

PARTS LIST

FC906 I

Pos	Service code	Description
1	4322 005 23000	Dustcover / Pr / Deep red
2	4322 003 29700	Dustcover lock / Select grey
3	4322 000 67810	DB detector spring
4	4322 003 23840	DB detector
5	4322 000 37300	Triple inletfilter
6	4322 003 23820	Inlet grille
7	4322 003 29800	Dustchamber / Select grey
8	4322 003 23650	Cordwinder Knob / Select grey
9	4322 000 09750	Pedal spring
10	4322 005 19550	DBFI/Valve assy Jewel FL
11	4322 003 23660	Vario knob / Select grey
12	4322 005 22990	Display c. Transp. Colourless / Pr
13	4322 003 29730	Button Panel / Deep red
14	4322 003 23900	Adjuster
15	4322 006 22740	PCB assy mb turn 220-240 V
16	4322 003 23640	Switch knob / Select grey
17	4322 003 29780	Back panel / Select grey
18	4322 003 29790	Cord outlet / Select grey
19	4322 003 29770	Lowerhousing back / Select grey
20	4322 003 29710	Lowerhousing / Deep red
21	4322 005 17010	Caster assy / Select grey
22	4322 005 15150	Cyl. ass. fra. blk / Li. purple
23	4322 003 24690	Filter cover lock / Select grey
24	4322 003 29740	Filter cover fr. / Deep red
25	4322 004 92910	Electrostatic filter Phoenix

Pos	Service code	Description
26	4322 001 73360	Exhaust sealing
27	4322 000 38790	Silencer 4 wall backpanel
28	4322 003 23220	S-class H-sealing
29	4322 000 38760	Silencer 1 wall
30	4322 000 38770	Silencer 2 bottom
31	4322 003 23880	Motorhousing top inside
32	4322 001 73520	Buffer back green
33	4322 001 73400	Bufferring fr. Ans-Atlas
34	4322 006 97940	Motor 1761 Domel 220-240 V
35	4322 000 38820	Silencer 3
36	4322 003 23870	Motorhousing Bottom ans
37	4322 009 07940	Reel half spring unit (L = 9 m)
38	4322 009 07950	Reel half contact unit
39	4322 009 07970	Contact ring plate
40	4322 006 01720	U.K. / H.K. L = 9.3 m
41	4322 006 01410	Euro 4.8 mm pins L = 9.3 m
42	4322 003 18850	Curved bend B1
43	4322 005 17090	Curved bend / Hose assy
44	4322 004 22510	Telescopic tube stand
45	4341 003 02470	Accessory clip
46	4322 004 22560	Small Nozzle
47	4322 004 23190	Tri-active Nozzle stand
48	4322 003 23830	DB-holder
49	4322 003 18870	Crevice Nozzle stand
50	4322 003 26030	Motor Bracket
51	4322 001 99120	Coupling bush
52	4322 007 45550	Coupling spring
53	4322 007 16000	Leaf spring assy

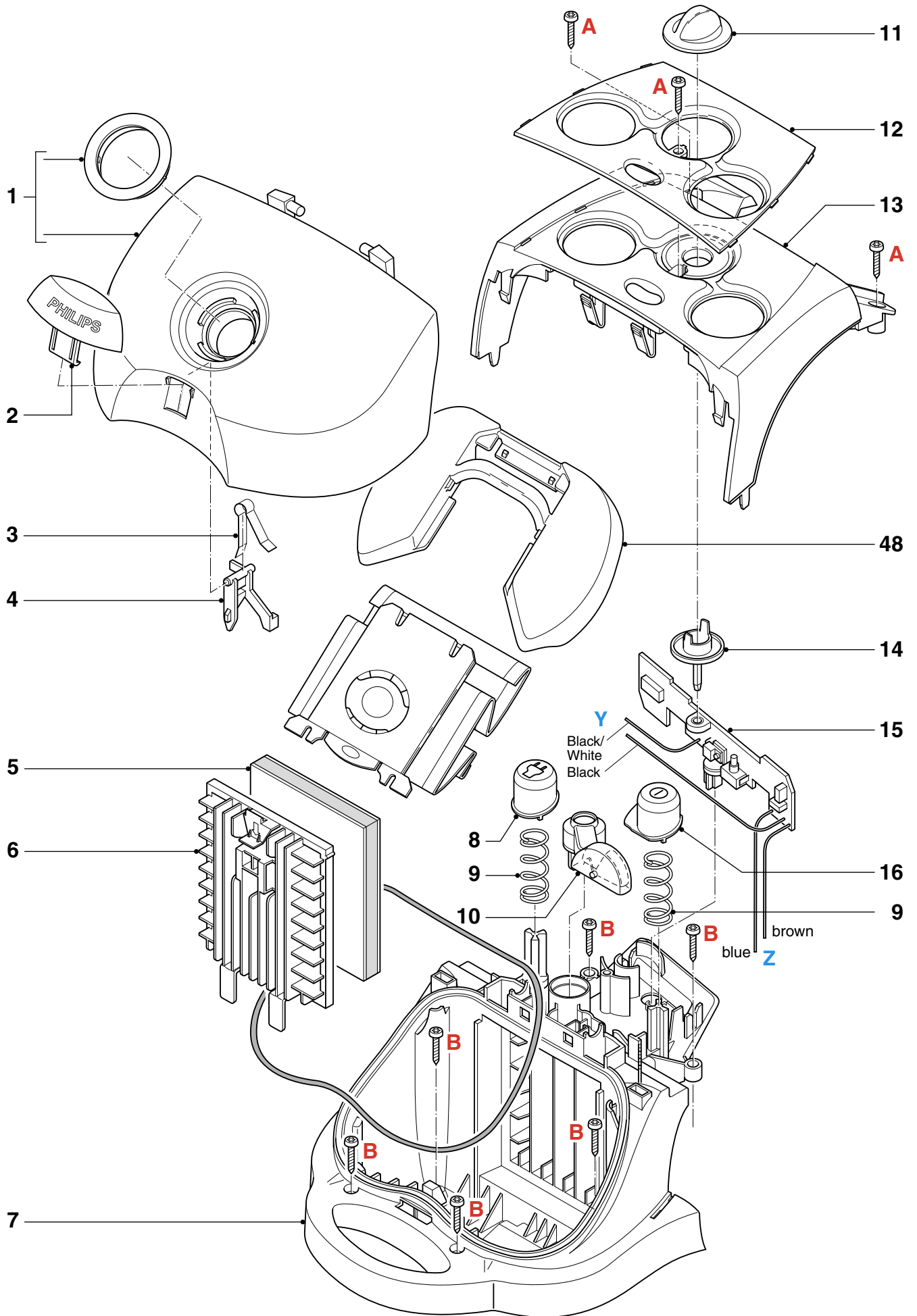

EXPLODED VIEW

FC906 I

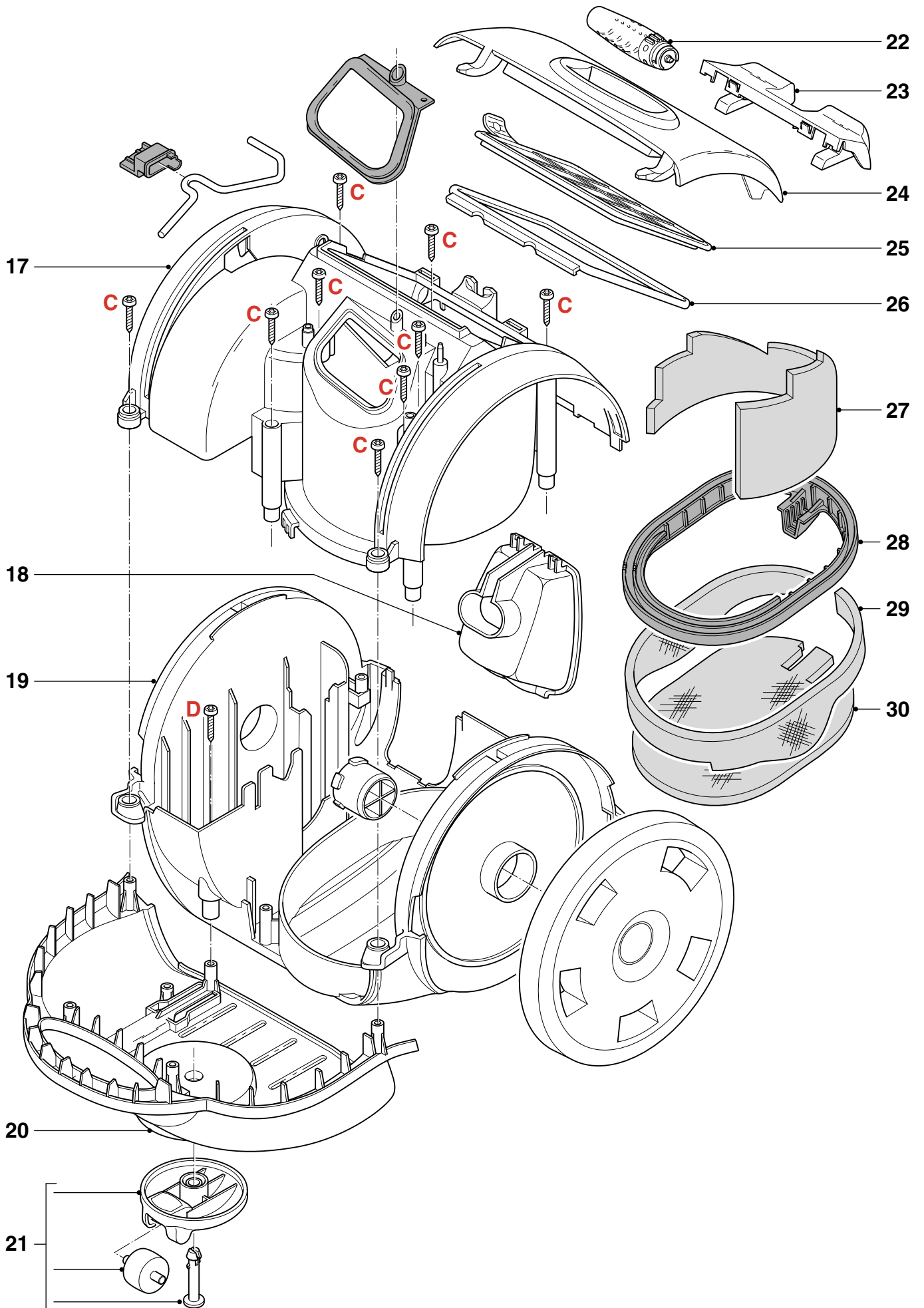

EXPLODED VIEW

FC906I

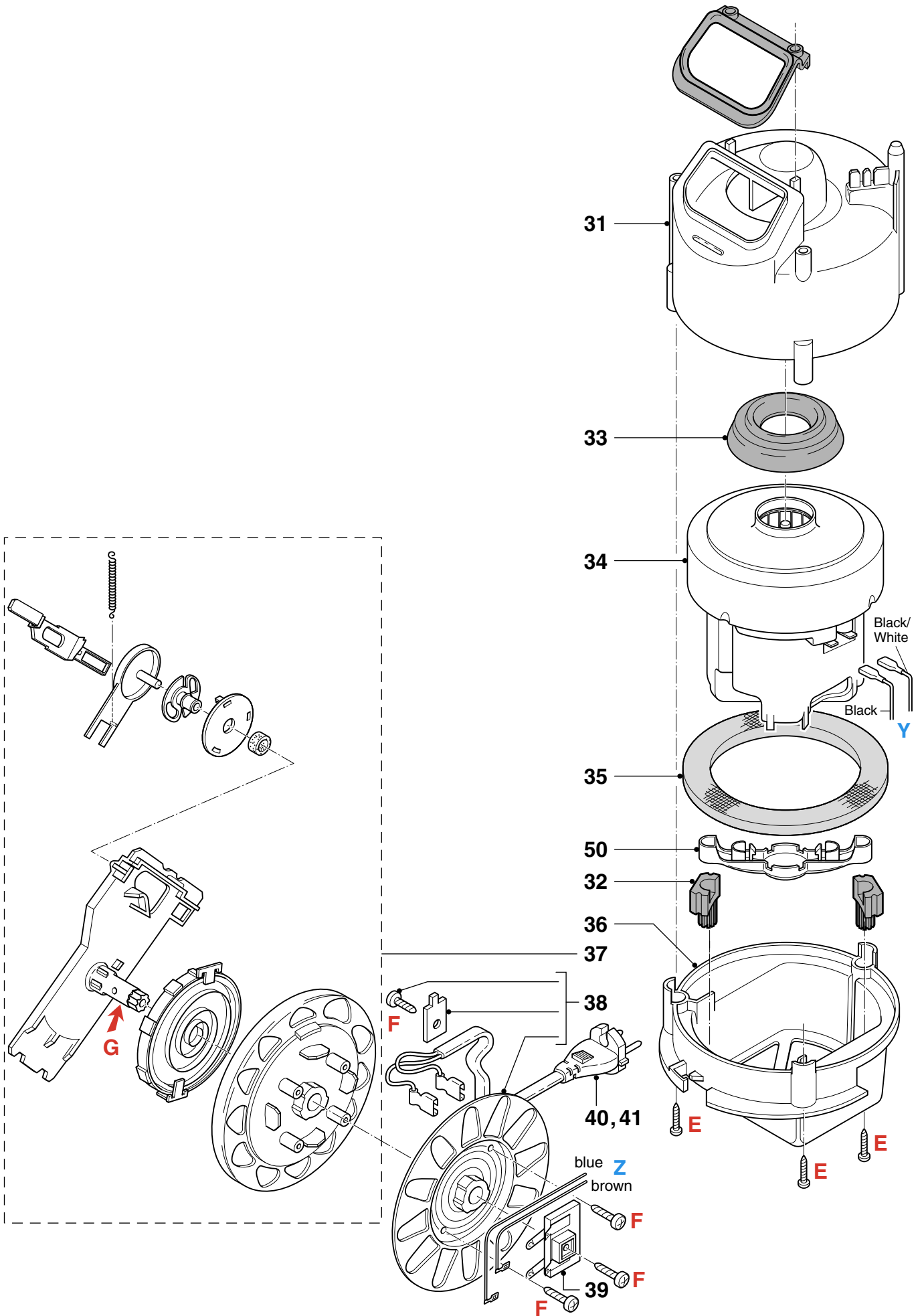

EXPLODED VIEW

FC906 I

